

Purpose:

The primary purpose of the Forward Artillery Controller (FAC) is to act as a gateway to the field infrastructure to allow your robot to request information about the state of the battle scene. Data on the status of the game and coordinates of ships/bots will be updated on the FAC from the field infrastructure at 10Hz.

Interface Connection

Connector:

The connector of the FAC is a 6-pin keyed Molex connector.

Pinout:

Pin	Name/Function
1	+5V (@ 100mA) / Power to the FAC (V_{dd})
2	SDI / Serial Data Into the FAC
3	SDO / Serial Data Out of the FAC
4	SCK / Serial Clock
5	SS / active low select line for the FAC
6	GND / Ground reference for the FAC



Electrical Specifications

Parameter	Min.	Max	Units
V_{iH}	$V_{dd} * 0.65$		V
V_{oH}	$V_{dd} - 0.4$		V
V_{iL}		$V_{dd} * 0.35$	V
V_{oL}		0.4	V
I_{iH}, I_{iL}		± 1	μA
I_{oH}	-20		μA
I_{oL}	20		μA
All Specifications at $V_{dd} = 5V$			

Byte Transfer Specification

The Forward Artillery Controller uses a synchronous serial signaling method to transfer data into and out of the FAC. The signaling method is compatible with SPI communications, with the FAC operating as a slave device on an SPI network. The \overline{SS} line must be lowered (asserted) to begin a 5-byte (40 bit) transfer and raised at the completion of the 5-byte transfer. The \overline{SS} line must remain de-asserted for a minimum of 2ms between transfers. The SDO line represents the serial data out of the FAC, while the SDI line represents serial data into the FAC.

The relationships between the four lines involved in the transfer of a byte are shown in the figure & table below:

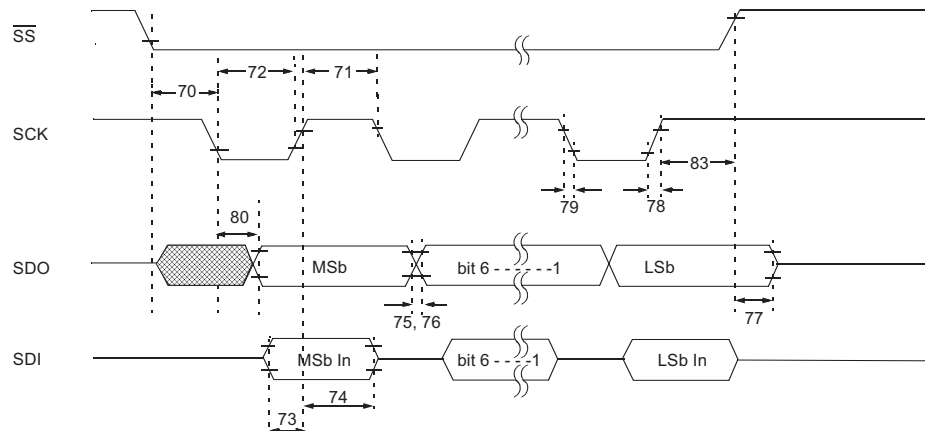

Forward Artillery Controller Documentation2

Param No.	Symbol	Characteristic	Min	Typ	Max	Units	Conditions
70*	TssL2sCH, TssL2sCL	$\overline{SS}\downarrow$ to SCK \downarrow or SCK \uparrow input	Tcy ^a	—	—	ns	
71*	TsCH	SCK input high time (Slave mode)	Tcy + 20	—	—	ns	
72*	TsCL	SCK input low time (Slave mode)	Tcy + 20	—	—	ns	
73*	TdIV2sCH, TdIV2sCL	Setup time of SDI data input to SCK edge	100	—	—	ns	
74*	TsCH2dIL, TsCL2dIL	Hold time of SDI data input to SCK edge	100	—	—	ns	
75*	TdoR	SDO data output rise time	3.0-5.5V	—	10	25	ns
			2.0-5.5V	—	25	50	ns
76*	TdoF	SDO data output fall time	—	10	25	ns	
77*	TssH2doZ	$\overline{SS}\uparrow$ to SDO output high-impedance	10	—	50	ns	
78*	TscR	SCK output rise time (Master mode)	3.0-5.5V	—	10	25	ns
			2.0-5.5V	—	25	50	ns
79*	TscF	SCK output fall time (Master mode)	—	10	25	ns	
80*	Tsch2doV, TscL2doV	SDO data output valid after SCK edge	3.0-5.5V	—	—	50	ns
			2.0-5.5V	—	—	145	ns
83*	Tsch2ssH, TscL2ssH	$\overline{SS}\uparrow$ after SCK edge	1.5Tcy + 40	—	—	ns	

* These parameters are characterized but not tested. ^aTcy = 33 μ S

Byte Level Protocol Specification

Common Byte Format:

Exchanges between the Forward Artillery Controller (FAC) and your robot take place with five successive bytes being exchanged. The first byte from the robot to the FAC is the actual command. The value returned from the FAC during this transfer will be 0x00, but has no meaning. The values sent to the FAC as the second through fifth bytes of the sequence should always be 0x00. The meanings of the values returned by the second through fifth byte transfers will be the results from the command byte.

Robot to Forward Artillery Controller Bytes:

The meaningful values for the command bytes from the robot to the Forward Artillery Controller are shown in the following table:

Command	Meaning
0x3F	Return the status of the game.
0xC3 – 0xE7	Return the coordinates of the ship/robot specified in the 6 LSBs of the command.

Forward Artillery Controller to Robot Bytes:

The values and meanings of the response bytes returned by the Forward Artillery Controller are shown in the following table:

Command	Response Bytes	Description of meaning
0x3F	0xFF, 0x00, 0x00, SS	SS = game status: 0x00 = stopped; bit 7 hi = red power station under repair, bit 6 high = blue power station under repair, 0x0A = game in play; 0x0B = game over, red won; 0x0C = game over blue won.
0xC3 – 0xE7	0xFF, XX, YY, RR	Co-ordinates of requested ship/'bot; XX = X co-ordinate, YY = Y co-ordinate, RR = orientation. If the requested ship/'bot is not currently visible, the FAC will return 0xFF, 0x00, 0x00, 0x00. The rotation reported for ships will always be 0x00.

Query the Status of the Game:

To query the game status, send a byte of 0x3F to the FAC followed by 4 bytes of 0x00. The FAC will process the query and during the four 0x00 bytes of the exchange will return 0xFF, followed by two bytes of 0x00 followed by the game status byte.

Query the Co-Ordinates of a Ship/Robot:

To query the co-ordinates of a particular ship/robot, form the necessary command byte value by bit-wise ORing 0xC0 with the number of the requested ship/robot (3-19, 20-29 or 30-39). Transmit the resulting command byte, followed by four bytes of 0x00. The values returned from the FAC during those four bytes of 0x00 will be, in order, 0xFF, the X co-ordinate, the Y co-ordinate and the rotation of the requested ship/'bot. Co-ordinates 0,0 are in the upper left corner of field, as shown in Fig. 1 of the project description(X:0 left-255 right, Y:0 up-255 down).

Rotation 0 is pointed up, parallel to the dividing wall shown in Fig. 1 of the project description (0 facing up-255 facing up again, counter clockwise).

Power on and reset behavior:

Initially, after power on or a reset, the Forward Artillery Controller will return 0xFF from any query until such time as the Forward Artillery Controller is internally initialized.

Command Timing:

The interval between two successive transfers from robot to Forward Artillery Controller should be at least 2ms.

The \overline{SS} line must remain high for a minimum of 2ms between successive transfers.

Invalid Command Bytes:

If the Forward Artillery Controller receives a command byte not listed in the table, it will respond to the invalid command byte by queuing a series of 0xFF bytes to be returned to the robot.

Sample Byte Sequence:

'Bot to FAC	0x3F	0x00	0x00	0x00	0x00	0xC3	0x00	0x00	0x00	0x00	0x4F	0x00	0x00	0x00	0x00
FAC to 'Bot	0x00	0xFF	0x00	0x00	0x0A	0x00	0xFF	0x27	0x50	0x10	0x00	0xFF	0xFF	0xFF	0xFF

In this sequence, the 'bot queries the game state(0x3F), which will return 0xFF, then two bytes of 0x00 followed by 0x0A if the game is in play. The next query (0xC3) is for the co-ordinates of the 'bot from team #3. The results from this query indicate that the 'bot is on the field at co-ordinates 39, 80 with an orientation of 16. The illegal query (0x4F) results in the FAC queuing a 0xFF, which will be returned on the first, and subsequent bytes of 0x00 from the 'bot.

Physical Specifications**Dimensions:**

The Forward Artillery Controller dimensions are 8.0" x 8.0" x 1.5".